



# KONVEKTA

Technical leadership starts with ideas.

## Technical manual

### Air conditioning heating system

### for MCV DD Hybrid



(BNK-MCVDD1-006)

**ID#: BEA-78443202A**  
**Version: A03**

**Konvekta AG**  
Am Nordbahnhof 5  
34613 Schwalmstadt  
Germany

☎ +49 (0) 66 91 / 76 – 0  
☎ +49 (0) 66 91 / 76 - 200  
✉ [Info@konvekta.com](mailto:Info@konvekta.com)  
[www.konvekta.com](http://www.konvekta.com)

## Contents

*Page:*

• <b>Directives for installation, connection and use.....</b>	<b>3</b>
• <b>Introduction .....</b>	<b>4</b>
<b>1. Technical data.....</b>	<b>5</b>
1.1. Components .....	5
1.2. Technical Data.....	5
<b>2. Components passenger compartment.....</b>	<b>6</b>
2.1. Cooling and heating for the upper deck VD4025.....	6
2.2. Heating for the lower deck HZ1403.....	7
2.3. Rear condenser HKD423/4.....	7
<b>3. Parameter HVAC system.....</b>	<b>8</b>
<b>4. Arrangement of the sensors .....</b>	<b>8</b>
4.1. Room sensor upper deck.....	8
4.2. Room sensor lower deck .....	9
4.3. Ambient-/Outdoor sensor.....	9
4.4. Water sensor .....	9
<b>5. Compressor driven by electric motor.....</b>	<b>10</b>
<b>6. Components driver's cab.....</b>	<b>11</b>
6.1. Evaporator VD2097/4 .....	11
<b>7. Driver climate control KS35.04 .....</b>	<b>11</b>
7.1. Introduction.....	11
7.2. Installation .....	11
7.3. Demounting .....	11
7.4. Self-test .....	12
7.5. Reset.....	12
7.6. Description rescr operating keys.....	12
7.7. Control elements.....	12
7.8. Operational description .....	12
7.8.1. Fan setting frontbox .....	12
7.8.2. Temperature setting a/c.....	13
7.8.3. A/C operation.....	13
7.8.4. Recirculating air flap a/c.....	13
7.8.5. Overview in- and outputs .....	13
<b>8. Maintenance.....</b>	<b>13</b>
<b>9. Warranty Conditions.....</b>	<b>14</b>
<b>10. Waste disposal in accordance with legal provisions .....</b>	<b>14</b>
<b>11. History of modification.....</b>	<b>14</b>

**Appendix:**

Wiring scheme BK1-600-470

Wiring scheme BK1-200-214

## Directives for installation, connection and use

Please read carefully the following instructions before installing, connecting and operating the devices. We assume no liability for incorrect handling and usage.

### **WARNING**

#### **MAKE THE CORRECT CONNECTIONS.**

Failure to make the proper connections may result in fire or product damage.

#### **USE ONLY SUITABLE VOLTAGE.**

The usage with insuitable voltage may result in fire. Furthermore insuitable voltage may result in failure or product damage.

#### **TAKE CARE THAT ELECTRICAL CABLES DO NOT CARRY CURRENT WHILE CONNECTING.**

Connecting cables which carry current may result in electrical short circuits or product damage.

#### **ONLY USE ADEQUATELY DIMENSIONED CABLES.**

Using cables with not sufficient large cross inadequate dimensions will exceed the current carrying capacity of the cables and result in fire or electric shock.

#### **DO NOT DISASSEMBLE OR ALTER.**

Doing so may result in an accident, fire or electric shock.

#### **DO NOT INSTALL IN LOCATIONS WHICH MIGHT HINDER VEHICLE OPERATIONS.**

Doing so may obstruct forward visibility or hampers movements and results in serious accidents.

#### **DO NOT BLOCK VENTS OR RADIATOR PANELS.**

Doing so may cause heat increasing inside and may result in fire.

#### **USE THE CORRECT AMPERE RATING WHEN REPLACING FUSES.**

Failure to do so may result in fire or electric shock.

#### **DO NOT PLACE HANDS, FINGERS OR FOREIGN OBJECTS IN INSERTION SLOTS OR GAPS.**

Doing so may result in personal injury or damage of the product.

#### **AVOID EXCESSIVE FORCE EFFECTS.**

Do not expose the device high to excessive force effects or strokes. Doing so may result in product damage.

#### **RANGE OF THESE DIRECTIVES.**

These directives apply for all devices, to which this directives-sheet is added. One directives-sheet is sufficient per box.

### **CAUTION**

#### **HAVE THE WIRING AND INSTALLATION DONE BY EXPERTS.**

The wiring and installation of this device requires special technical skill and experience and have to be done by experts.

#### **ARRANGE THE WIRING SO IT IS NOT CRIMPED OR PINCHED BY A SHARP METAL EDGE.**

Arrange the wiring so it will not be damaged.

#### **DO NOT INSTALL IN LOCATIONS WITH HIGH MOISTURE OR DUST.**

Avoid installing the device in locations with high incidence of moisture or dust. Moisture or dust that penetrates into this device may result in product failure or damage.

#### **USE SPECIFIED ACCESSORY PARTS AND INSTALL THEM SECURELY.**

Be sure to use the specified accessory parts. Use of other than designated parts may damage this device internally or may not securely install the device in place.

#### **STOP USE IMMEDIATELY IF A PROBLEM APPEARS.**

Failure to do so may cause personal injury or damage to the product. Return it to your authorized customer service.

#### **TEMPERATURE.**

Be sure the environment-temperature is in the allowed range before start-up of device.

#### **USE DEVICE ONLY FOR SPECIFIED APPLICATION AREA.**

Using the device for another purpose or in another application area than the intended one, may result failure, product damage or injury.

#### **PRODUCT CLEANING.**

Use a soft dry cloth for cleaning the device. For more severe dirt, please dampen the cloth with water only. Anything else has the chance of damage the product.

#### **TRANSPORT TERMS**

Handle the unit with care at any time. During transport make sure that the unit is stored safely and cannot be damaged. If more than one unit are transported, every unit has to be packed singly to avoid that the units damage one another.

The forwarder is liable for all damages during transport.

## Introduction

This technical manual has been written for drivers, operators and maintenance staff of your air conditioning heating system.

**Please observe our valid safety instructions, available under [www.konvekta.de/asv.html](http://www.konvekta.de/asv.html). In case of order placement or any other conclusion of contract the safety instructions get integral part of the contract.**

**In this context, we refer implicitly to the compliance with our general installation guidelines. These can be obtained from the KONVEKTA technical after sales service: [TKD@konvekta.com](mailto:TKD@konvekta.com).**

These instructions have to be read carefully and made use of before the first start-up and after that regularly by each person who is involved in handling the machine.

This facilitates the handling and avoids trouble caused by improper operation. Working in compliance with these operating instructions increases operation reliability and service life of the air conditioning unit and reduces life cycle costs.

**Please complete these instructions by adding the national provisions for prevention of accidents and environmental protection.**

You will certainly understand that we will not accept any warranty claims due to improper handling, inadequate maintenance, applications that do not correspond with the determined use, utilization of not admitted fuels or the non-observance of safety provisions. **KONVEKTA** will cancel without pre-notice all obligations concerning guarantee, service contracts etc. regardless if granted by **KONVEKTA** or its distributors in case others than original **KONVEKTA** spare parts or parts bought from **KONVEKTA AG** have been used for maintenance and repair. This operating instruction contains all necessary information to operate your air conditioner. In case you need more explanations please contact: ☎ +00 49 6691 / 76-124 or via Email: [TKD@konvekta.com](mailto:TKD@konvekta.com).

**The machine stands in accordance with the EC machinery directive 2006/42/EC.**

**The unit contains or needs fluorinated greenhouse gas for operation and is subject to identification requirements in accordance with F-Gas Regulation 517/2014.**

In the course of further developments we reserve the right to technical modifications without notice. Guarantee and liability conditions of KONVEKTA AG's general business conditions are not enlarged by the above notes.

Indications and photos should neither be copied and circulated nor used for competitor's purposes. All rights according to the copyright remain expressly reserved.

**Manufacturer: KONVEKTA AG, P.O. Box 2280, D-34607 Schwalmstadt**



### **Danger of accidents!**

Qualified staff in charge of installation and maintenance have to be trained in accordance with EN 378-Part 4 and (EC) No.307/2008 and must strictly follow the legal provisions.

Any works or modifications on the air conditioner which are carried out improperly can lead to malfunction and so endanger operational reliability. We recommend having all works and modifications carried out by an authorized **KONVEKTA** Service Station.

**Before carrying out any maintenance works on your air conditioning unit, carefully read the KONVEKTA safety provisions (TD00052A<sup>®</sup>) in order to avoid any dangers and accidents!**



**The way of installation depends on the vehicle type; the instructions of the manufacturer have to be considered!**

### Please note:

- All screwed joints must generally be tested for leaks.
- Tightening torques for O-ring connections according to instructions AA07050122.
- Country-specific/regional accident prevention regulations must be observed (e.g. for Germany BGV 29).
- Vehicles may only be repaired observing the generally accepted technical standards and the manufacturer's operating instructions. In addition, the company may only entrust repair, conversion or retrofit work which requires specialist knowledge to suitable companies or suitably qualified people guaranteed by the company or under their supervision.

## 1. Technical data

### **Important!**

In vehicles that are equipped with an a/c unit with heating function the heating medium has to consist of water/glycol – antifreeze protection 50/50 %. This is absolutely necessary to prevent the heaters from frost damage! (The prevalent antifreeze filling of the vehicle manufacturers goes down to -40 °C)

### 1.1. Components

<b>Passenger compartment</b>		Konvekta Art. No.
Cooling and heating upper deck	Evaporator VD4025	B78-090024-432
	Rear condenser HKD423	B76-125024-436
	Compressor TM22	H13-000-851
Heating lower deck	Heater HZ1403	B75-1400241403
	Climate control KN305	H11-005-481
<b>Driver's cab</b>		
	Evaporator VD2097/4	B78-070024A301
	Control KS35.04	H11-005-431

### 1.2. Technical Data

<b>Refrigerant</b>		R 134a
<b>GWP</b>		1.430
<b>Refrigerant quantity for the complete HVAC system:</b>	<i>kg</i>	2,5
<b>Operating voltage</b>	<i>Volt DC</i>	24
<b>Evaporator VD4025</b>	<b>cooling capacity:</b>	<i>Watt</i> 9.000
	<b>heating capacity:</b>	<i>Watt</i> 15.000
	<b>air volume:</b>	<i>m³/h</i> 2.400
<b>Heater HZ1403</b>	<b>heating capacity (Q100):</b>	<i>Watt</i> 14.000
	<b>air volume:</b>	<i>m³/h</i> 1.290
<b>Rear condenser HKD423</b>	<b>cooling capacity:</b>	<i>Watt</i> 12.500
	<b>air volume:</b>	<i>m³/h</i> 4.000
<b>Evaporator VD2097/4</b>	<b>cooling capacity:</b>	<i>Watt</i> 7.200
	<b>heating capacity (Q100):</b>	<i>Watt</i> 20.000
	<b>air volume:</b>	<i>m³/h</i> 1.050
<b>Compressor</b>		TM21/22

## 2. Components passenger compartment

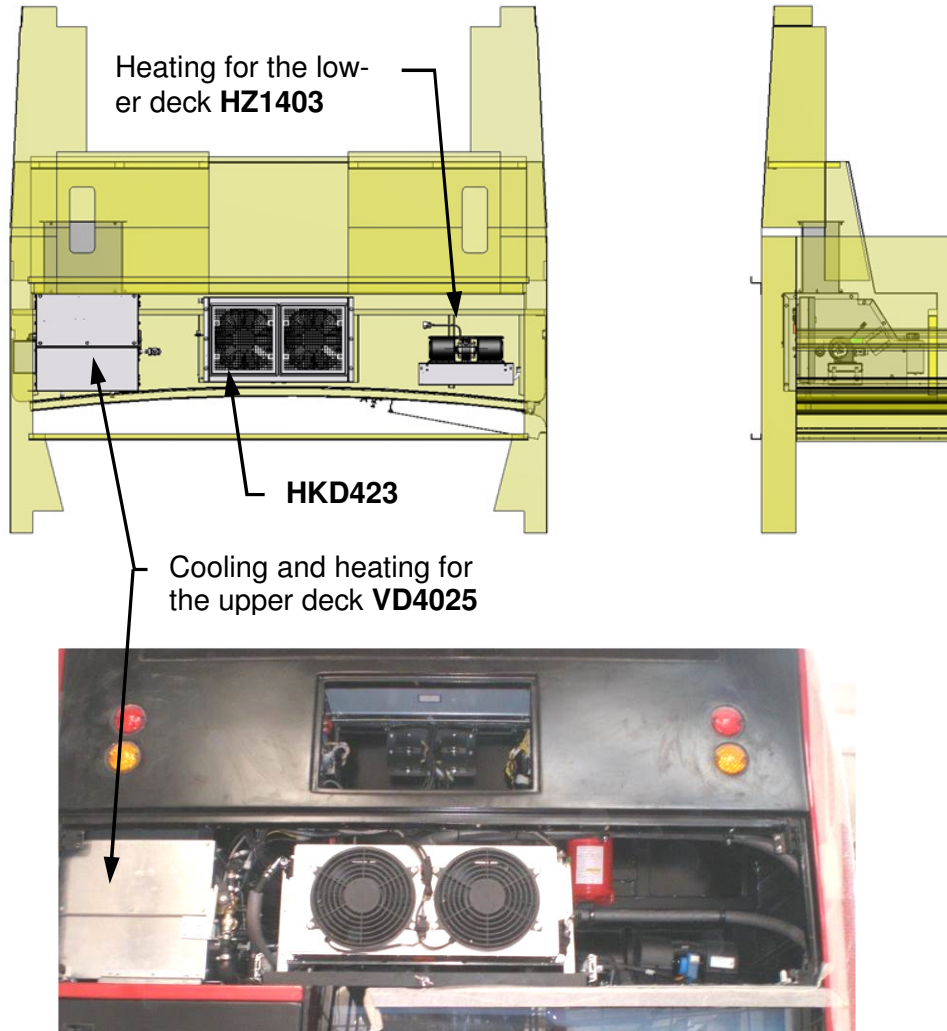

### 2.1. Cooling and heating for the upper deck VD4025

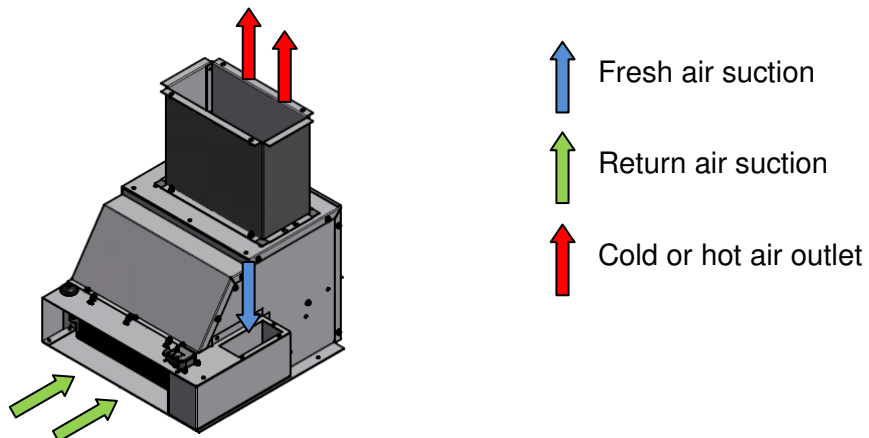

**2.2. Heating for the lower deck HZ1403**

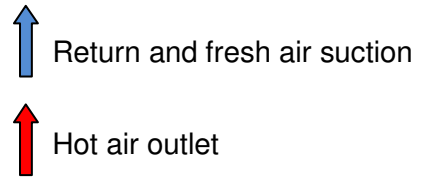
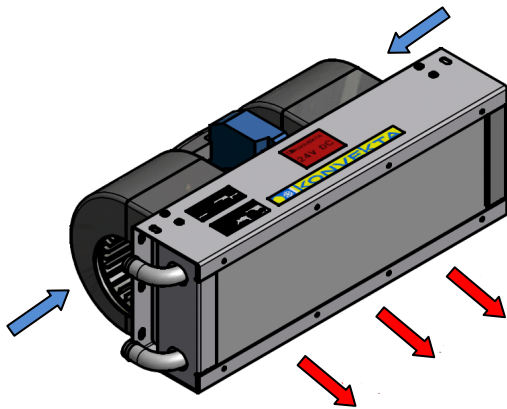

**Engine compartment**

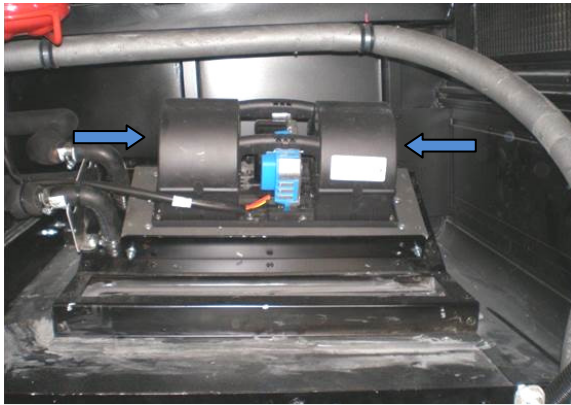

**Passenger compartment**

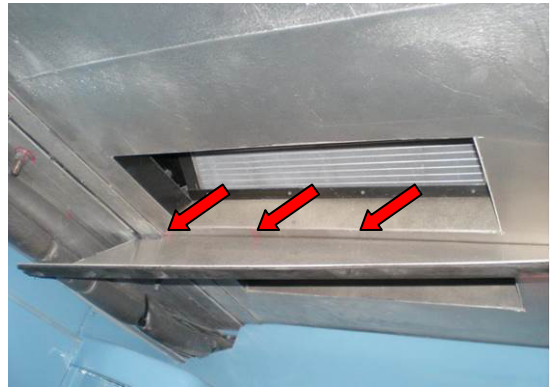

**2.3. Rear condenser HKD423/4**

Condenser suction

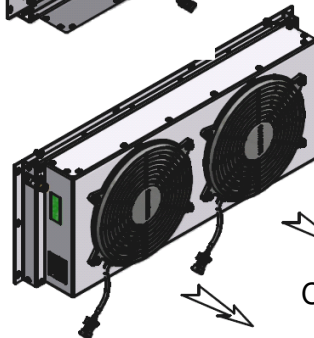
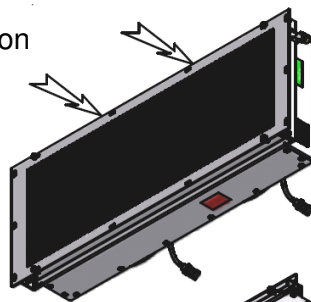

Condenser air outlet

### 3. Parameter HVAC system

#### HVAC control system KN305 on MCV DD100

Until 05/17	.... - 11°C	11°C – 15°C	15°C – 21°C	21°C – 26°C	26°C – ....
From 05/17	.... - 11°C	11°C – 17°C	17°C – 23°C	23°C – 26°C	26°C – ....
<b>Water pump</b>	on	on	off	off	off
<b>Heating valve</b>	on	on	off	off	off
<b>Blower speed step 2</b>	on	off	off	off	on
<b>Blower speed step 1</b>	on	on	on	on	on
<b>Condenser fan</b>	off	off	off	on	on
<b>Compressor-clutch</b>	off	off	off	on	on
	Return air	Return air	Fresh air	Return air	Return air
<b>Flap heating lower deck</b>	on	on	off	off	off

*Water pump is available as an option.*

Sensor ambient temperature lower deck >>responsible for blower speed  
 Sensor ambient temperature upper deck >>responsible for cooling mode on  
 Sensor outside temperature >>compressor is locked, when outside temp. <10°C  
 Sensor water circuit >>heating system is locked, when water temp. <50°C

Hysteresis heating – cooling – ventilation +/- 1°C  
 Prerequisite ignition ON + engine ON (D+)

### 4. Arrangement of the sensors

#### 4.1. Room sensor upper deck

The room sensor upper deck is located on the air duct in driving direction right side, in the middle of the vehicle.

**Attention:** Sensor must be well insulated from side of air duct channel.

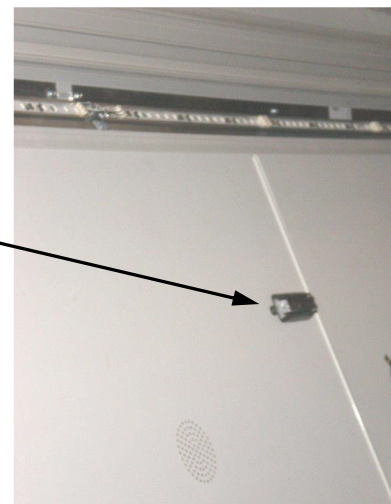



#### 4.2. Room sensor lower deck

The room sensor lower deck is located on the cover-panel in the driving direction left in the middle of the vehicle.



#### 4.3. Ambient-/Outdoor sensor

The ambient-/outdoor sensor is located at the fresh air grid in driving direction, left side.



#### 4.4. Water sensor

The water sensor is located on the hot water pipe in the engine room.

**Attention:** Sensor must be well insulated to the pipeline.



## 5. Compressor driven by electric motor

Konvekta item no.:	H13-000-851
Type:	TM21/22 / 8 PV
Refrigerant:	HFC-134a
Permissible speed:	700 ~ 6.000 r/min
Direction of rotation:	Clockwise or anticlockwise
Weight:	8,476 kg

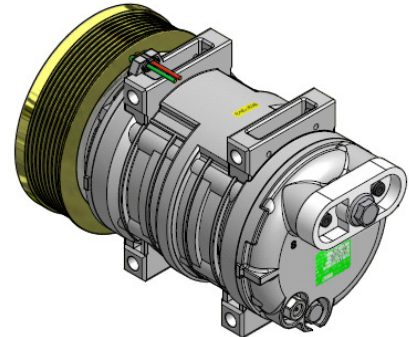

### **Important:**

#### **To avoid leakages at the shaft seal of the compressor:**

The compressor should be started every 4 weeks for rescri. 15 minutes!

This also applies when the vehicle is not into operation for a longer period or when the air conditioning unit is not used!

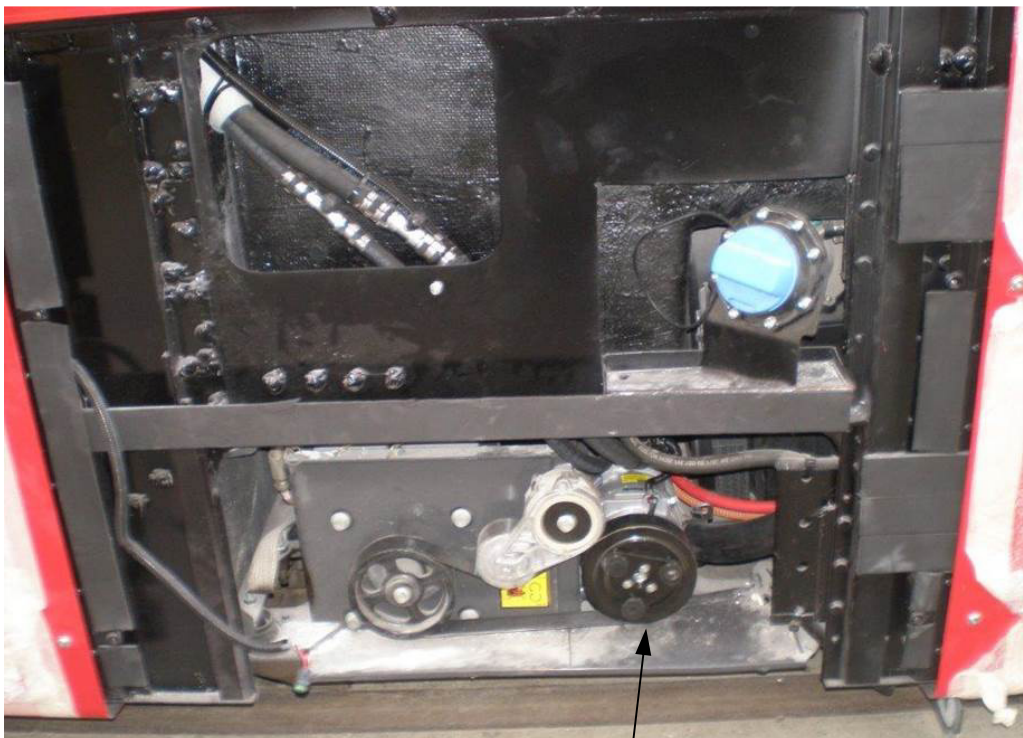

Compressor TM21/22

## 6. Components driver's cab

### 6.1. Evaporator VD2097/4

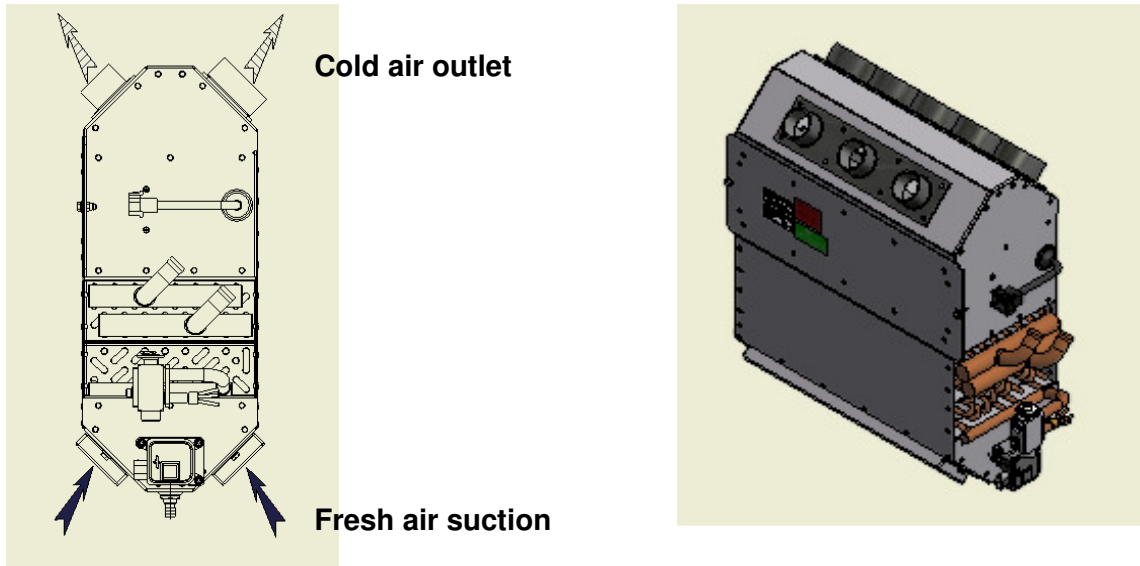

## 7. Driver climate control KS35.04

### 7.1. Introduction

The air conditioning control **KS35.04** is a control and regulation device in radio size for air conditioning units in modern buses, which – thanks to its compact design – can be easily integrated in the vehicle's dashboard. The bus driver is relieved from all questions of an optimum air conditioning in the passengers' compartment by a simple and clear handling.

The following keys/switches are used to control the air conditioning unit:

Key for manual control (S1)

Key for the recirculating air flap (S2)

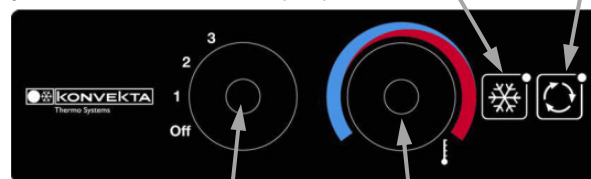

Rotary switch for the three-step blowers

Rotary switch to adjust the temperature

- ✓ Keypad with yellow background lighting.
- ✓ The digital outputs DA01 to DA06 are short-circuit-tested.
- ✓ The digital outputs DA07 + DA08 have to be protected by suitable pre-fusing.

### 7.2. Installation

1. After carrying out the installation (cables laid out along the vehicle and 24-pole connecting plug positioned in the dashboard control seat), the control frame has to be fitted and inserted into the dashboard opening.
2. Connect the plug to the control unit and insert the control unit into the frame

### 7.3. Demounting

For demounting the control a customary unlocking clamp is needed.

## 7.4. Self-test

If the power supply to the controller is disconnected a self-test is carried out after connecting the power supply again. All inputs and outputs are checked. If parts of the air conditioning unit (water valves, sensors) are replaced a self-test has to be carried out to calibrate the controller.

## 7.5. Reset

By pressing key S1 (a/c) for 15 seconds a reset is carried out to start the self-test.

## 7.6. Description rescr operating keys

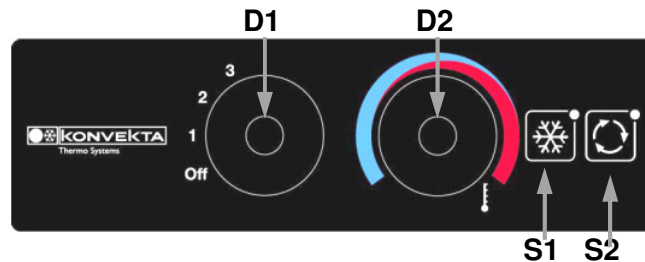

Symbol	Function
<b>D1</b>	Rotary switch for the air capacity driver's seat 0 – 1 – 2 – 3.
<b>D2</b>	Rotary switch for set temperature 12 to 32 degree.
<b>Key S1</b>	Climate is activated – Reset.
<b>Key S2</b>	Key to switch the recirculating air flap on circulating air.

## 7.7. Control elements

### Rotary switch 1:

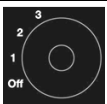

With this rotary switch the air capacity to the driver's seat is adjusted 0 -1- 2 -3. If step 1 is selected the rotary switch (c contact) sends back a signal to the controller (DE03 release a/c).

### Rotary switch 2:



With this rotary switch the set temperature from 12° to 32° C is adjusted. Left stop – valve is closed 0%. Right stop – valve is 100% open.

### Key S1:



With key S1 the a/c is activated if the external release signal A/C of blower switch is sent.

**RESET:** By pressing key S1 (a/c) for 15 seconds a reset is carried out to start the self- test.

### Key S2:



With key S2 the air flap is moved into recirculating mode. The excitation is provided for a VMC 2. The digital outputs turn off after 15 seconds to prevent from damage.

## 7.8. Operational description

**=> A/c frontbox is only operational when the ignition is switched on.**

### 7.8.1. Fan setting frontbox

The frontbox blower is adjusted with the rotary switch 0 – 1 – 2 – 3. If step 1 is selected, the rotary switch (c contact) sends back a signal to the controller (DE03 release a/c) to activate a/c operation.

**Note:** Because a mechanical switch is mounted the logic has to be effected with ignition and alternator.

### 7.8.2. Temperature setting a/c

- Via the rotary switch a set temperature from 12° to 32° C is preset.
- Left stop – control is deactivated, valve is closed 0%.
- Right stop – control is activated, valve 100% open.
- The sensor in the return air compares the actual temperature with the set temperature.
- The duct sensor in the air outlet controls the heating valve.

### 7.8.3. A/C operation

With key S1 the compressor is switched on manually, if there is the release signal via the blower switch.

Via the digital input DE02, the feedback signal HD (high pressure)/ND (low pressure) of the compressor is checked.

In case of fault the red LED of key S2 flashes.

**A/C ON:** Ignition ON + press S1.

**A/C OFF:** deactivate S1 (if ignition off, no climate function).

### 7.8.4. Recirculating air flap a/c

With key S2 and if ignition is ON, the air flap can be set to recirculating mode. The digital outputs are turned off 15 seconds after the servo motor has reached its position.

### 7.8.5. Overview in- and outputs

6	Digital outputs a 200 mA	20-30V
2	Digital outputs 3Amp .	20-30V
3	Digital inputs	20-30V
1	Valve potentiometer input	0-5V
2	Sensor input	0-5V

## 8. Maintenance

Maintenance intervals	Maintenance operation	Comments	Expenditure of time (min)
Monthly	Clean air cleaner FB		5
Monthly	Clean air cleaner „Saloon“		5
		total (min)	10
Every 3 months	Replace air cleaner FB		5
Every 3 months	Replace air cleaner „Saloon“		5
		total (min)	10
Every 12 months	Check v-belt at compressor	If worn renew	5
Every 12 months	Check function HP switch	OFF: 25,5 bar (+/-1)	15
Every 12 months	Replace dryer / collector	Including evacuating and filling	120
Every 12 months	Functional check heating / cooling		15
Every 12 months	Sight check refrigerant lines	For abrasions	10
Every 12 months	Sight check of cables and fuses		10
Every 12 months	Sight check of all heat exchanger for dirt	Clean if necessary	15
		total (min)	190

## 9. Warranty Conditions

The current „General Warranty Conditions“ KONVEKTA AG“ will apply. A copy will be furnished by the warranty department. Please contact [gwl@konvekta.com](mailto:gwl@konvekta.com).

## 10. Waste disposal in accordance with legal provisions

**After the phase of use the last proprietor is responsible for the adequate waste management. The environmental regulations in the exporting country must be observed.**

The following list contains the most important regulating literature, valid for the *Federal Rep. of Germany*:

- Resolution for dangerous substances
- Law for waste circulation (KRW/AfgG))
- Resolution for the proofs of utilization and removal
- Criminal Code (StGB) 28th section „criminal acts against the environment“ §326 – Environment jeopardizing waste management
- Law of chemicals § 27 – penal rescriptions
- Resolution for used oil
- Law of water balance
- Resolution for the waste management of old cars and the adaptation of road prescriptions
- Resolution (EC) No. 2037/2000 of the European Parliament and of the Council for materials that affect the ozone layer
- Resolution to prohibit certain ozone destroying halogen hydrocarbons.

The used refrigerant endangers the environment. When dealing with refrigerants the existing prescriptions and regulations are to be followed. **Only qualified staff is allowed to carry out these works!**

Water endangering substances – acc. To §§19g-19l – are solid, liquid, and gaseous substances. E.g.: mineral and tar oils (cooling oils), halogen containing organic combinations (refrigerants).

---

© Source of supply:  
 - Bundesanzeiger  
 - Beuth Verlag  
 - dtv (Deutscher Taschenbuch Verlag)

## 11. History of modification

Version	Date	Name	Remark	File
A00	18.05.2016	B. Kessler	Source file	EA78443202A
A01	17.01.2017	B. Keßler	Point 3 water pump as an option; Points 4.2 and 4.3 updated	EA78443202A
A02	12.06.2017	B. Keßler	Introduction and point 1.2 updated according to F-gas regulation	EA78443202A
A03	29.06.2017	B. Keßler	Point 3 table updated	EA78443202A